

LOCTITE® TEROSON®

Vehicle Repair &
Maintenance Solutions

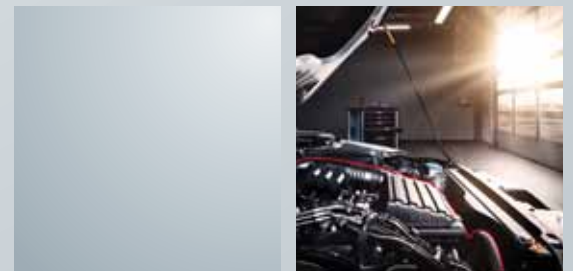

Excellence is our Passion

LOCTITE® is the world's #1 brand of engineering adhesives & sealants

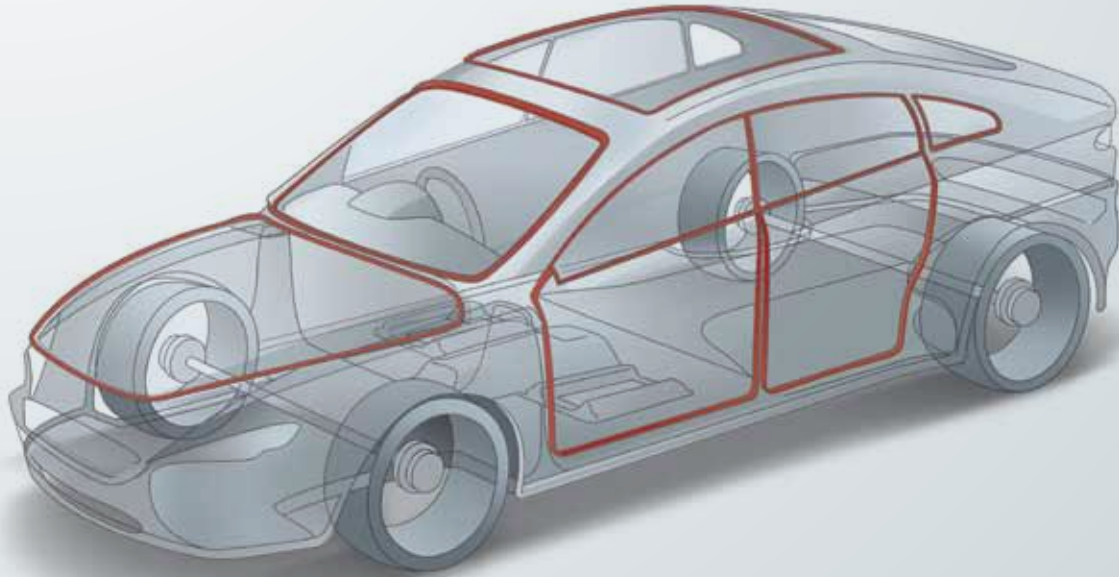

End-User Training	Value-Added Partnership	Global Leadership	Superior Product Performance	Cost Savings and Reliability
We provide professional training programs to customers that help them identify opportunities for improving process efficiency, quality and costs.	Our large, experienced team of engineers provide documented design and application support.	LOCTITE® is the global technology leader with wide product range sold through an extensive sales and distributor network.	LOCTITE® adhesives and sealants are recognized as the best performing products in the industry.	LOCTITE® solutions are more cost effective compared to conventional mechanical methods.

Henkel : Workshop Solutions Provider



→ We are focused in delivering **quality, reliability** and **cost savings**.

- | | |
|---|-------------------------------|
| <input checked="" type="checkbox"/> Improve repair quality | >> Differentiated services |
| <input checked="" type="checkbox"/> Increase workshop profit | >> More income and efficiency |
| <input checked="" type="checkbox"/> Improve customer satisfaction | >> Better loyalty (CSI) |

Henkel OES & Automotive Aftermarket Partners

TATA	MARUTI	MAHINDRA	FORD	HYUNDAI	ASHOK LEYLAND
NEW HOLLAND	JCB	MERCEDES-BENZ	BMW	GM	MITSUBISHI
MOTORS	PORSCHE	TOYOTA	LAND ROVER	VOLKSWAGEN	JAGUAR
CHERY	GEELY	HAIMA	SUBARU	and many more...	

LOCTITE®

Body Shop Repair and Refinish Solutions



Henkel brings solutions ranging from bonding and sealing to bodyfillers, under body coating; plastic repair to sound deadening and direct glazing.

Trusted by service technicians across the globe for bringing safety, reliability and high performance to all vehicle repair applications; these solutions offer the same quality as automotive OEMs get who use these products during vehicle manufacturing.



POLISHES



- ▶ Rubbing compound to remove wet sanding marks
- ▶ Glazing material to remove compounding & swirl marks
- ▶ Paint gloss protective wax coating

BODYFILLER



- ▶ For all repair jobs like dents, scratches and small holes
- ▶ Easy sanding so that original shape may be restored
- ▶ Semiflexible and able to withstand body movement, vibration and minor knocks
- ▶ Excellent adhesion to metal / glass reinforced plastics

DIRECT GLAZING ADHESIVES



- ▶ Excellent bonding and strength
- ▶ Cost saving and higher productivity due to lower turnaround time
- ▶ Easy to apply
- ▶ Primers and primerless variants available

SEAM SEALANTS



- ▶ Excellent elastic sealing on multiple substrates
- ▶ Rapid skin formation
- ▶ Vibration absorbing properties
- ▶ Can be painted over
- ▶ Easy to apply

UNDER BODY COATING



- ▶ Permanently elastic corrosion protection
- ▶ Protection against stone chips
- ▶ High abrasion resistance
- ▶ Suitable for sound deadening
- ▶ Bitumen free

For more information call : **1800 2333 562** or send your enquiry on www.henkel.in/enquiry

Henkel Adhesive Technologies India Pvt. Ltd.

Kesar Solitaire, 11th floor, Plot no. 5, Sector-19, Palm Beach Road, Navi Mumbai Maharashtra - 400 705, India

Tel. : +91-22-3929 6600/1 | www.henkel.in | www.loctite.in





Mechanical Service and Repair Solutions

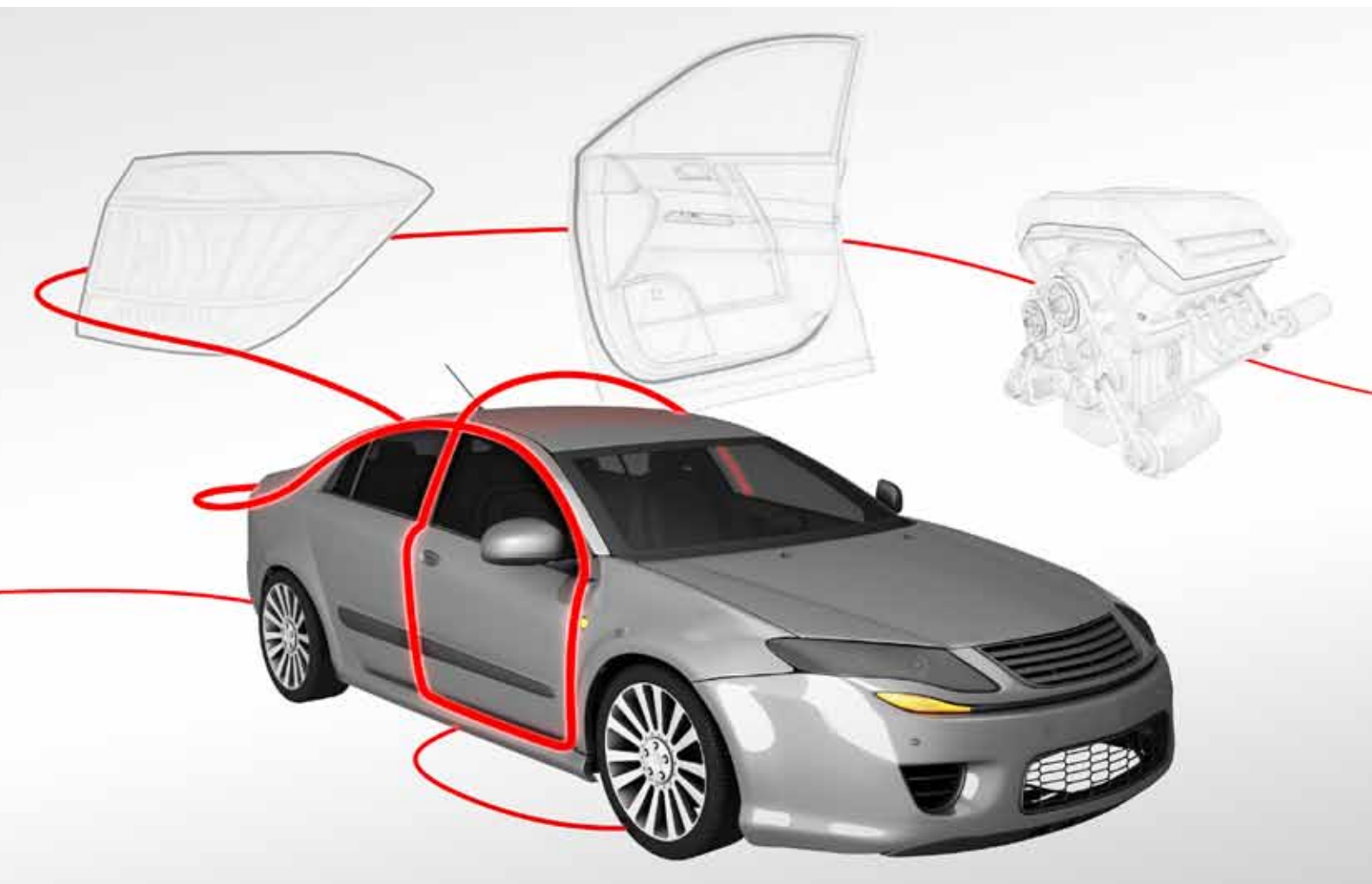

Henkel's Loctite® and Teroson® brands offer a comprehensive product range to ensure reliability of mechanical assemblies.

Solutions ranging from threadlocking, gasketing, instant bonding, structural bonding, cleaning and lubrication, help service technicians ensure fast, reliable and safe servicing.



THREADLOCKING & SEALING



- ▶ Invented by Loctite® to lock and seal threaded fasteners
- ▶ Specified by Automotive OEM's
- ▶ Works by filling the spaces between threads
- ▶ Provide a secure, one piece assembly that will not loosen under stress
- ▶ Provide an instant, low pressure seal for metal pipes and fittings
- ▶ Will not creep, shrink or block systems by shredding

GASKETING COMPOUNDS



- ▶ Fills imperfections, providing 100% sealing
- ▶ No relaxation, creeping or cracking
- ▶ Makes gasket in any shape or size
- ▶ Low inventory, labour and machining costs

RETAINING COMPOUNDS



- ▶ Bonds non-threaded, cylindrical metal assemblies
- ▶ Less close tolerance required
- ▶ 100% contact leads to even load distribution
- ▶ No corrosion between metal parts

LUBRICANTS & CLEANERS



- ▶ Superior performance
- ▶ More active ingredients
- ▶ Effective and targeted application designed for various car parts

For more information call : **1800 2333 562** or send your enquiry on www.henkel.in/enquiry

Henkel Adhesive Technologies India Pvt. Ltd.

Kesar Solitaire, 11th floor, Plot no. 5, Sector-19, Palm Beach Road, Navi Mumbai Maharashtra - 400 705, India

Tel. : +91-22-3929 6600/1 | www.henkel.in | www.loctite.in



TEROSON®

Polishing Compounds



- ▶ Removes scratches and sanding marks
- ▶ Excellent glossy final finish
- ▶ Offers complete range
- ▶ Gives protection to painted surface
- ▶ Easy to apply, convenient packaging



Application Steps



1. Sanding



2. Rubbing & Haze Removal



3. Wax Polishing



4. Final Wiping

Rubbing Compounds



Teroson® WX 150 (Fast Cut)

Pack Size 1 l
IDH No. 1675020

APPLICATIONS

1. Rubbing Compound
2. Removes 2000 grit sanding marks

BENEFITS

1. Fast removal of light sanding marks & high gloss
2. Minimal dust residues and clean work place
3. Suitable for all original and repair coatings
4. Better suited for lighter paint error, scratches



Teroson® WX 157 (Heavy Cut HP)

Pack Size 1 kg
IDH No. 1675017

APPLICATIONS

1. Rubbing Compound
2. Removes 1500-2000 grit sanding marks

BENEFITS

1. Fast removal of light sanding marks & high gloss
2. Minimal dust residues and clean work place
3. Suitable for all original and repair coatings
4. Optimal quantity required, covers maximum area

Finishing Compounds



Teroson® WX 175 Glaze HP

Pack Size 1 l
IDH No. 1675022

APPLICATIONS

1. Haze & Swirl marks remover
3. For perfect finish glaze

BENEFITS

1. Hologram free mirror finish
2. Removes swirl marks from rubbing process
3. Low dust contamination and clean work place
4. Versatile, suitable for all coatings



Teroson® WX 180 Polish Wax

Pack Size 1 l
IDH No. 796923

APPLICATIONS

1. Shine
2. Protective wax polish

BENEFITS

1. Gives original wet look to paint
2. Long-term protection of paint gloss
3. Deep shine and high gloss
4. Easy to apply
5. Perfect mirror finish
6. Protects painted surface with natural wax

For more information call : **1800 2333 562** or send your enquiry on www.henkel.in/enquiry

Henkel Adhesive Technologies India Pvt. Ltd.

Kesar Solitaire, 11th floor, Plot no. 5, Sector-19, Palm Beach Road, Navi Mumbai Maharashtra - 400 705, India

Tel. : +91-22-3929 6600/1 | www.henkel.in | www.loctite.in



TEROSON®

Teroson® UP 450

Universal Body Filler



Teroson® UP 450 is an adhesive product used to “fill” dents, scratches, holes and surface imperfections in body work prior to painting. Once applied and painted, body work will show no evidence of earlier damage.

Benefits

- ▶ Maximum coverage with optimal quantity
- ▶ Semiflexible with ability to withstand body movement, vibration and minor knocks
- ▶ Excellent adhesion to metal/glass reinforced plastics
- ▶ Easy to apply, shape and sand
- ▶ Excellent build quality
- ▶ Smooth finish

Application Areas

- ▶ For all repair jobs like dents, scratches and small holes





How to Use



Surface Preparation & Mixing

1. Remove existing film exposing an area 5 mm wider than the area to be repaired.
2. Thoroughly clean and degrease sanded area. Wash with detergent and water. Dry with clean cloth to remove surface contamination.
3. Use gentle folding action to mix hardener without adding air, till fully blended into paste.



Application

1. Use clean spreader to apply thin layer of mixed filler to the metal surface.
2. Press filler paste into grooves caused by sanding.
3. Ensure no air is trapped and avoid leaving excess ridges of filler around the sanded area.

Need it Now?



Teroson[®] UP 450

IDH No. : 1907219

Pack Size : 1 kg

For more information call : **1800 2333 562** or send your enquiry on www.henkel.in/enquiry

Henkel Adhesive Technologies India Pvt. Ltd.

Kesar Solitaire, 11th floor, Plot no. 5, Sector-19, Palm Beach Road, Navi Mumbai Maharashtra - 400 705, India

Tel. : +91-22-3929 6600/1 | www.henkel.in | www.loctite.in



TEROSON®

Teroson® PU 9092 PL Primerless Direct Glazing Kit



Teroson® PU 9092 PL is one part high strength and high viscosity modified polyurethane sealant. that can be applied easily and cures fast to provide reliable performance.

Benefits

No Primer	High Thixotropy	Versatile Bonding
Lower Turnaround Time	Ease of Application	Excellent Strength
Cost Savings	Better Bonding	Variety of Materials



Quick Set



High Viscosity



Moisture Cure

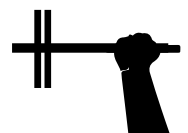

High Strength





How to Use



Surface Preparation

The substrates must be dry, clean, free of oil and other contaminants that could adversely affect the bonding performance. A thin layer approx 1mm of freshly trimmed older adhesive is recommended to be kept intact.



Application

Apply TEROSON® PU 9092 PL along the windshield edge. Then place the windshield on it and press before it starts curing. Tools used should be cleaned with MEK or Acetone before curing. After curing, mechanical cleaning is necessary.

Need it Now?



Teroson® PU 9092 PL

IDH No. : 1905876

Pack Size : 310 ml Cartridge

For more information call : **1800 2333 562** or send your enquiry on www.henkel.in/enquiry

Henkel Adhesive Technologies India Pvt. Ltd.

Kesar Solitaire, 11th floor, Plot no. 5, Sector-19, Palm Beach Road, Navi Mumbai Maharashtra - 400 705, India

Tel. : +91-22-3929 6600/1 | www.henkel.in | www.loctite.in



TEROSON®

Teroson® PU 8590 Kit

Direct Glazing Adhesive Kit



Teroson® PU 8590 is a high viscous direct glazing adhesive used for windscreen bonding. Recommended and used by most Indian as well as multi-national auto manufacturers. The nine component pre-measured kit, ensures error free surface preparation and application.

Benefits

- ▶ Short setting time leads to faster turn around
- ▶ Excellent UV resistance (retains elasticity even after aging)
- ▶ Higher reliability due to 100% bonding of substrates
- ▶ Excellent strength of bonding on multiple substrates
- ▶ Solvent - free composition

Application Areas

- ▶ Bonding of front, rear and side windscreens to vehicle body





How to Use



Surface Preparation

1. Clean substrates to be bonded and ensure they are dry, free from oil, dust etc. Use Henkel cleaner (Teroson® 8550) provided in kit. 2. Apply Henkel primer from kit (Teroson® PU 8511) to both glass & frame, using brush provided and allow to dry for 5 minutes.



Application

1. Cut nozzle provided to required length (depending on thickness of bead required). 2. Apply Teroson® PU 8590 in a triangular bead using cartridge hand gun, along the windshield edge. 3. Position windscreen and press into place using rubber spacers.

Need it Now?



Teroson® PU 8590 Kit

IDH No. : 1574212

Pack Size : 310 ml

For more information call : **1800 2333 562** or send your enquiry on www.henkel.in/enquiry

Henkel Adhesive Technologies India Pvt. Ltd.

Kesar Solitaire, 11th floor, Plot no. 5, Sector-19, Palm Beach Road, Navi Mumbai Maharashtra - 400 705, India

Tel. : +91-22-3929 6600/1 | www.henkel.in | www.loctite.in



TEROSON[®]

Seam Sealants



- ▶ OEM texture refinish for all vehicles
- ▶ Excellent bonding and sealing of joints, interior and exterior seams
- ▶ Wide range of solutions available based on over-painting requirements and application areas
- ▶ High UV resistance and good weathering performance
- ▶ Provides protection to components from shock, constant vibration, flexing, thermal expansion or contraction.



OEM
Grade



Teroson® MS 930

Colour	Pack Size	IDH
Grey	310 ml	1656500
White	310 ml	1656499

APPLICATIONS

Recommended for seam and joint sealing in vehicle body, flexible and elastic sealing for interior and exterior application

BENEFITS

1. Soft elastic sealing
2. 100% gap seal
3. UV and weathering resistant
4. Can be painted over
5. Non corrosive and free of solvent



Teroson® PU 9108

Pack Size	IDH No.
280 ml	1546523

APPLICATIONS

Recommended for seam sealing and sealing of narrow joints in vehicle body (interior or exterior application)

BENEFITS

1. Good adhesion to painted surfaces, many metals and plastics without primer
2. Can be painted over
3. Excellent elasticity in sealing
4. Sag resistant
5. Value range

How to Use



Surface Preparation

1. The substrates must be dry, clean, free of oil and other contaminants.
2. Cleaners, primers or activators suitable for the selected product should be used for best performance of product.



Application

1. Apply the selected product from its cartridge using a pneumatic or hand gun with an air pressure of 2 to 5 bar.
2. Paint compatibility has to be tested before use.

For more information call : **1800 2333 562** or send your enquiry on www.henkel.in/enquiry

Henkel Adhesive Technologies India Pvt. Ltd.

Kesar Solitaire, 11th floor, Plot no. 5, Sector-19, Palm Beach Road, Navi Mumbai Maharashtra - 400 705, India

Tel. : +91-22-3929 6600/1 | www.henkel.in | www.loctite.in



TEROSON®

Teroson® RB 2010

Underbody Coating



Teroson® RB 2010 underbody coating is extremely dependable and resilient. It offers excellent resistance to both abrasion, corrosion and provides several acoustic benefits.

Benefits

- ▶ Bitumen free
- ▶ Permanently elastic corrosion protection
- ▶ Protection against stone chips
- ▶ High abrasion resistance
- ▶ Suitable for sound deadening

Application Areas

- ▶ Repair work of underbody
- ▶ Protection of wheel house, front/rear aprons, door sills against road stones
- ▶ Sound dampening of wheel houses and side walls





How to Use



Surface Preparation

1. Clean surface to be coated. Ensure surface is dry, free from grease, dirt, dust and rust. 2. In case of new vehicles, protective wax must be steam cleaned. 3. In case of older vehicles, rust should be removed with wire brush.



Application

1. Shake Teroson® RB 2010 can well, before use and apply with Teroson® UBC pistol at pressure of 4 to 5 bars. 2. Spray in criss-cross fashion. 3. Allow drying time of at least 2-4 hours before vehicle use. Final drying may need 24-48 hours. 4. Clean pistol and purge after use. Ensure pistol is unclogged before spraying.

Need it Now?



Teroson® RB 2010

IDH No. : 1905664

Pack Size : 1 kg

For more information call : **1800 2333 562** or send your enquiry on www.henkel.in/enquiry

Henkel Adhesive Technologies India Pvt. Ltd.

Kesar Solitaire, 11th floor, Plot no. 5, Sector-19, Palm Beach Road, Navi Mumbai Maharashtra - 400 705, India

Tel. : +91-22-3929 6600/1 | www.henkel.in | www.loctite.in



Threadlockers and Thread Sealants



Threadlockers

- ▶ Invented by Loctite® to lock and seal threaded fasteners
- ▶ Specified by Automotive OEM's
- ▶ Works by filling the spaces between threads
- ▶ Provide a secure, one piece assembly that will not loosen under stress

Thread Sealants

- ▶ Provide an instant, low pressure seal for metal pipes and fittings
- ▶ Will not creep, shrink or block systems by shredding

Threadlockers

Low Strength



Loctite® 222

Pack Size 50 ml
250 ml

IDH No. 848063
848062

APPLICATIONS

1. Screws
2. Countersunk head screws and set screws
3. Collars pulleys
4. Tool holders and controllers

BENEFITS

1. For low strength applications
2. Locks and seals small screws and fasteners under 1/4"
3. Allows disassembly with normal tools

Medium Strength



Loctite® 243

Pack Size 50 ml
250 ml

IDH No. 1367282
531707

APPLICATIONS

1. Flywheel bolts
2. Crown wheel bolts
3. Crankshaft nuts
4. Threaded fasteners
5. Oil drain plugs

BENEFITS

1. Locks and seals bolts, nuts and studs upto 3/4" and prevent loosening from vibration
2. Allows disassembly with normal tools
3. Effective on all types of metal threaded fasteners
4. Tolerates thread lubrication, anti-corrosion and protection fluids

High Strength



Loctite® 2701

Pack Size 50 ml
250 ml

IDH No. 864526
864527

APPLICATIONS

1. Studs in gear boxes
2. Cylinder blocks

BENEFITS

1. For maximum threadlocking strength of bolts, nuts and studs
2. For permanently locking assemblies which must not come loose
3. Seal Fasteners
4. Can be disassembled by heating to 300°C

Fine Threads



Loctite® 542

Pack Size 50 ml
250 ml

IDH No. 848735
848736

APPLICATIONS

1. Hydraulic threaded fittings
2. Small pneumatic fittings up to R 3/4"

BENEFITS

1. Suitable for sealing fine threads.
2. Seals and locks in any position allowing parts to be easily aligned

Coarse Threads



Loctite® 577

Pack Size 50 ml
250 ml

IDH No. 848742
848741

APPLICATIONS

1. Air line fittings
2. Pneumatic systems

BENEFITS

1. Medium strength pipe sealant for sealing coarse threads.
2. Provides instant sealing advantage

Thread Sealants

For more information call : **1800 2333 562** or send your enquiry on www.henkel.in/enquiry

Henkel Adhesive Technologies India Pvt. Ltd.

Kesar Solitaire, 11th floor, Plot no. 5, Sector-19, Palm Beach Road, Navi Mumbai Maharashtra - 400 705, India

Tel. : +91-22-3929 6600/1 | www.henkel.in | www.loctite.in





Gasketing Compounds

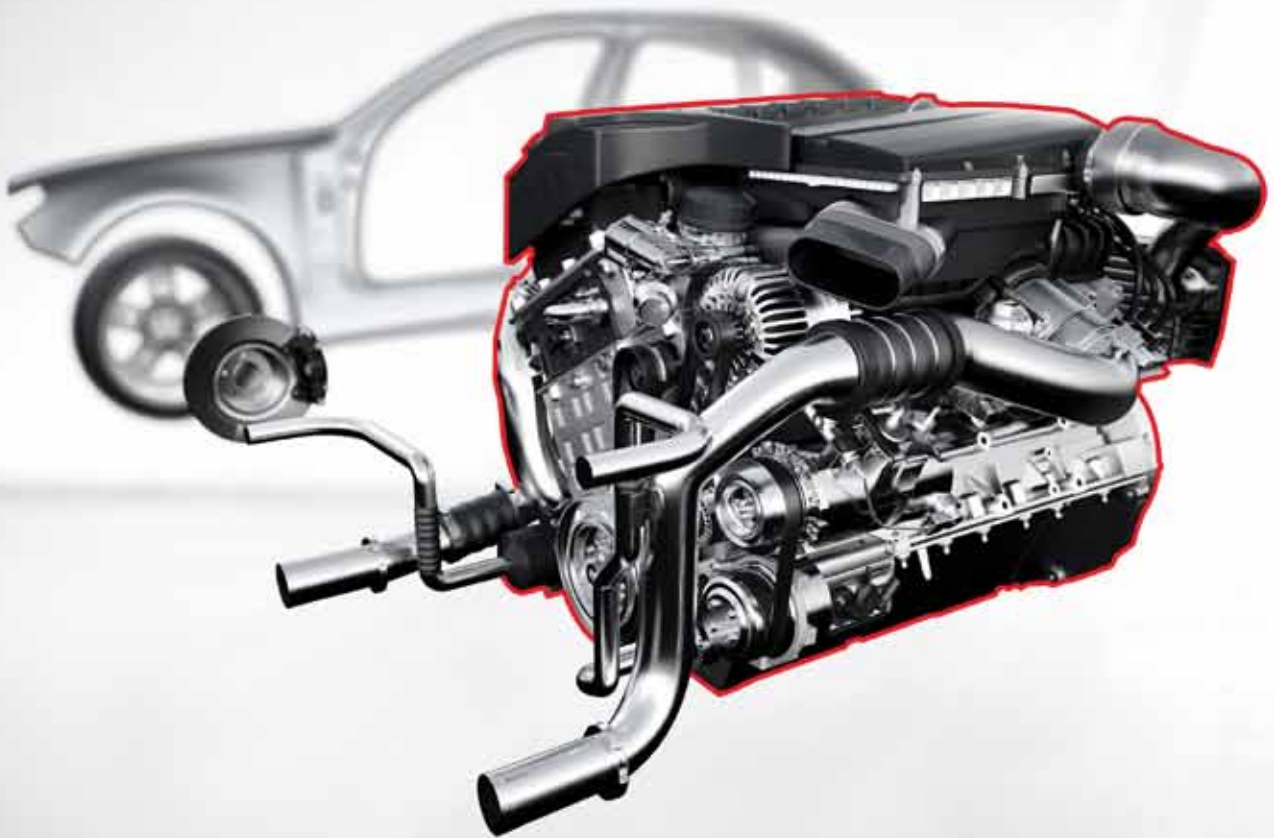

Gasketing Compounds

- ▶ Makes gaskets of any shape or size
- ▶ Fills imperfection
- ▶ Provides 100% sealing
- ▶ No relaxation or cracking
- ▶ Low inventory, labour and machining cost
- ▶ Wide range of solutions suitable for different thread types, flange types etc available



Flexible Flanges

Oil
Tolerant



Loctite® SI 5910

Pack Size 50 ml
IDH No. 1752556

APPLICATIONS

Recommended for stamped sheet metal covers (timing covers and oil sumps) where good oil resistance and ability to withstand high joint movement is required

BENEFITS

1. High Adhesion
2. Wide service temperature range (-40° C to 232° C)
3. Gasket maker with high oil tolerance to automotive engine oils
4. Gap fill

Valve
Seal



Loctite® Superflex 24

Colour	Pack Size	IDH
Grey	25	1616705
	85	1616799
Red	25	1616707
	85	1616706
White	25	1616702
	85	1616704

APPLICATIONS

1. Recommended for sealing all types of flanges including sheet metal
2. Especially suited for applications where high temperature resistance is required

BENEFITS

1. No irritating odour (like acetoxy cure silicones) as it is a neutral cure silicone
2. Wide service temperature range upto 260° C

Oil
Tolerant



Loctite® SI 587 BL

Pack Size 95 gm
IDH No. 1266356

APPLICATIONS

Recommended for sealing all types of flanges including stamped sheet metal, valve cover, locker cover, oil pans, end seals & rare axle housing

BENEFITS

1. Gasket maker with high oil tolerance to automotive engine oils
2. Wide service temperature range (-59° C to 260° C)
3. Adapts to flange surfaces and scratches up to 6.35mm

Fast
Cure



Loctite® 574

Pack Size 250 ml
IDH No. 848734

APPLICATIONS

Recommended for sealing rigid and semi rigid metal flange

BENEFITS

1. Fast curing with instant sealing
2. Adapts to flange surfaces and scratches up to 0.25mm
3. Recommended for high strength applications.

Flexible
Application



Loctite® 515

Pack Size 50 ml
IDH No. 833769

APPLICATIONS

For sealing rigid flanges with less than 0.39 mm gap. Applicable on flanges that move in service or aluminum flanges

BENEFITS

1. Better able to withstand vibration
2. Adapts to flange surfaces and scratches up to 0.39 mm
3. Wide service temperature range (-59° C to 260° C)

Rigid Flanges

For more information call : **1800 2333 562** or send your enquiry on www.henkel.in/enquiry

Henkel Adhesive Technologies India Pvt. Ltd.

Kesar Solitaire, 11th floor, Plot no. 5, Sector-19, Palm Beach Road, Navi Mumbai Maharashtra - 400 705, India

Tel. : +91-22-3929 6600/1 | www.henkel.in | www.loctite.in



Retaining Compounds



Retaining Compounds

- ▶ Bonds non-threaded, cylindrical metal assemblies
- ▶ Less close tolerance required
- ▶ 100% contact leads to even load distribution
- ▶ No corrosion between metal parts

Oil Tolerant

Loctite® 603



Pack Size
50 ml
250 ml

IDH No.
865328
1712323

APPLICATIONS

1. Retains cylinder linings
2. Roller bearings
3. Oil impregnated bushings

BENEFITS

1. For high strength applications requiring tolerance to surface contamination such as oils etc
2. Fills clearance in repaired parts upto 0.1 mm
3. Seals assemblies and prevents fretting corrosion
4. Difficult to disassemble with normal tools

High Gap

Loctite® 638



Pack Size
50 ml
250 ml

IDH No.
1865160
1865048

APPLICATIONS

For loose-fitting parts such as

1. Shaft
2. Gear
3. Pulleys

BENEFITS

1. For high-strength assemblies
2. Fills clearance in repaired parts upto 0.25 mm
3. Seals assemblies and prevents fretting corrosion
4. Difficult to disassemble with normal tools

Close fitting parts

Loctite® 648



Pack Size
50 ml
250 ml

IDH No.
1865163
1865164

APPLICATIONS

1. Splined shafts
2. Bearings
3. Steering systems components
4. Gearings
5. Cylindrical parts

BENEFITS

1. Fills clearance in repaired parts upto 0.15 mm
2. Seals assemblies and prevents fretting corrosion
3. Difficult to disassemble with normal tools
4. Recommended for continuous working temperatures upto 149°C

High Loads

Loctite® 680



Pack Size
50 ml
250 ml

IDH No.
1865165
1865167

APPLICATIONS

1. Shafts
2. Gears
3. Pulleys

BENEFITS

1. Suited for applications which face high dynamic, aerial and radial loads
2. Fills clearance in repaired parts upto 0.4 mm

For more information call : **1800 2333 562** or send your enquiry on www.henkel.in/enquiry

Henkel Adhesive Technologies India Pvt. Ltd.

Kesar Solitaire, 11th floor, Plot no. 5, Sector-19, Palm Beach Road, Navi Mumbai Maharashtra - 400 705, India

Tel. : +91-22-3929 6600/1 | www.henkel.in | www.loctite.in





Lubricants, Cleaners & Degreasers

Loctite® SF 3013
Weld Through Primer

Loctite® SF 7262
Carb & Throttle Cleaner

Loctite® LB 7737
Rust Bust

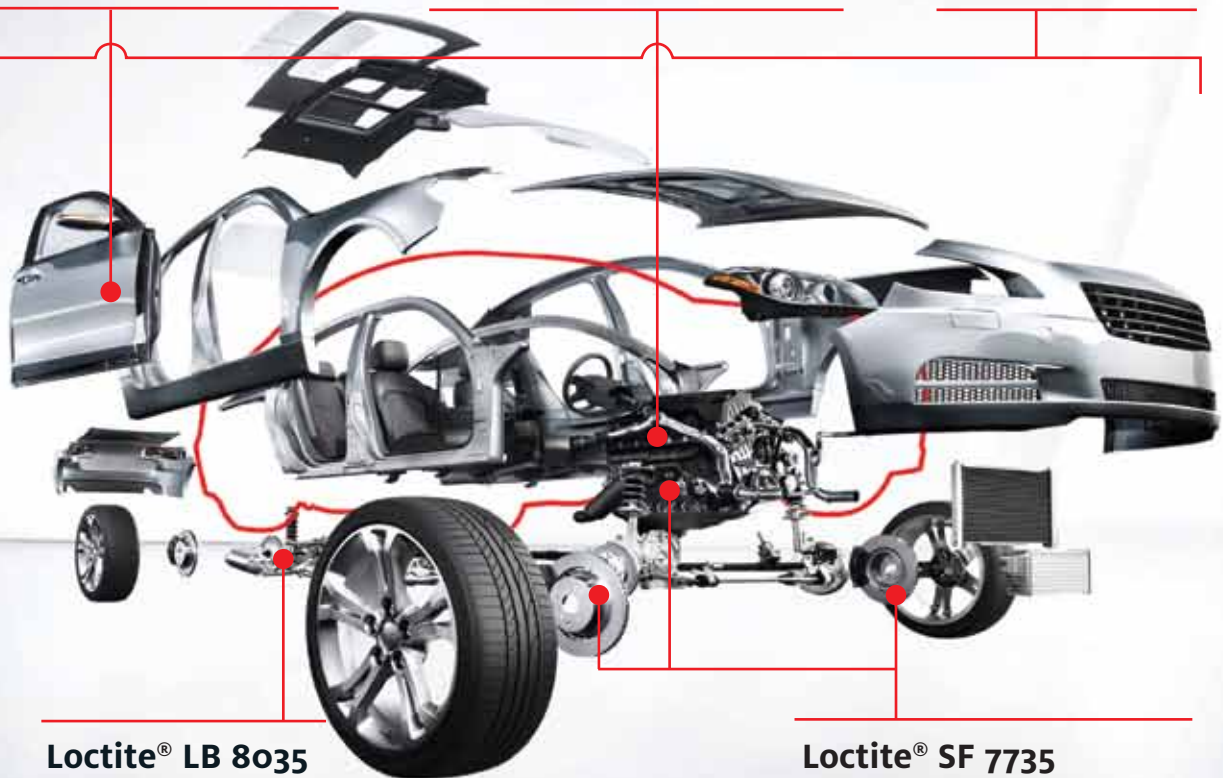

Loctite® LB 8035
Synthetic Grease

Loctite® SF 7735
Brake & Clutch Cleaner

- ▶ Superior performance
- ▶ More active ingredients
- ▶ Effective and targeted application designed for various car parts





**Loctite® SF 3013
Weld Through Primer**

Pack Size **IDH No.**
300 gm 1673787

- APPLICATIONS**
1. Welded joints
 2. Silencer coating

- BENEFITS**
1. Rust inhibitor primer
 2. Temperature resistance upto 250°C
 3. Protective coating without flaking



**Loctite® SF 7262
Carb & Throttle Cleaner**

Pack Size **IDH No.**
70 gm 1644282
315 gm 1788108
350 gm 1644280

- APPLICATIONS**
1. Carburetor jets
 2. Throttle body

- BENEFITS**
1. Carburetor & Throttle parts cleaner
 2. Efficient residue removal
 3. Engine efficiency improvement



**Loctite® LB 7737
Rust Bust**

Pack Size **IDH No.**
70 gm 1644275
315 gm 1909755
350 gm 1644299

- APPLICATIONS**
1. Nuts
 2. Bolts
 3. Rust prone joints
 4. Hinges

- BENEFITS**
1. Rust loosening
 2. Moisture displacement
 3. Protection & Lubrication



**Loctite® LB 8035
Synthetic Grease**

Pack Size **IDH No.**
350 gm 1644283

- APPLICATIONS**
1. Bearings
 2. Valves
 3. Hinges
 4. Open gears

- BENEFITS**
1. Non dripping, non staining lubricant
 2. Instant maintenance and protection
 3. Long lasting lubricating film



**Loctite® SF 7735
Brake & Clutch Cleaner**

Pack Size **IDH No.**
350 gm 1644278

- APPLICATIONS**
1. Brake cables
 2. Liners
 3. Pads
 4. Clutch components

- BENEFITS**
1. Efficient brake & clutch parts cleaner
 2. Residue removal
 3. Brake efficiency & effectiveness improvement
 4. Restore friction of brake & clutch lining



**Loctite® SF 7263
Chain Lube**

Pack Size **IDH No.**
70 gm 1644300

- APPLICATIONS**
1. Gear
 2. Chain
 3. Cable
 4. Wire rope

- BENEFITS**
1. Non dripping, non staining lubricant
 2. Instant maintenance and protection
 3. Long lasting lubricating film

For more information call : **1800 2333 562** or send your enquiry on www.henkel.in/enquiry

Henkel Adhesive Technologies India Pvt. Ltd.

Kesar Solitaire, 11th floor, Plot no. 5, Sector-19, Palm Beach Road, Navi Mumbai Maharashtra - 400 705, India

Tel. : +91-22-3929 6600/1 | www.henkel.in | www.loctite.in



LOCTITE[®]
BONDERITE[®]
TECHNOMELT[®]
TEROSON[®]
AQUENCE[®]

Henkel Adhesive Technologies India Private Limited

Mumbai

Corporate Office

10th Floor, Kesar Solitaire,
Plot No. 5, Sector - 19, Sanpada,
Navi Mumbai - 400705,
Maharashtra, India
Phone : +91 22 3929 6600

Pune

Survey No. 234, 235 and 245,
Phase 1, Hinjewadi,
Pune - 411 057
Maharashtra, India
Phone : +91 020 3980 3100

Chennai

Arunodayam, No. 14 & 16,
Raman Street, North Boag Road,
T. Nagar, Chennai - 600 017,
Tamil Nadu, India
Phone : +91 44 3354 6123

Delhi

407, 4th Floor, Centrum Plaza,
Opp. Suncity Business Tower,
Golf Course Road, Sector - 53,
Gurgaon - 122 002.
Phone : +91 124 385 1102

Factory

D3/D4, MIDC Industrial Estate,
Jejuri - 412 303. Pune District
Maharashtra, India
Phone : +91 0211 530 0017